



How to Handle Nail Salon Waste in King County

Waste acetone and certain other chemicals used in nail salons are considered hazardous wastes and must be managed and disposed of safely. This brochure describes how to manage some nail salon wastes. It is not intended to be a complete reference to all regulations relevant to nail salons and does not list all hazardous chemicals found in salons. Ultimately, responsibility for proper handling and disposal of waste belongs to the owner of the nail salon.

Used Cotton Balls

Store cotton balls that have acetone, nail polish remover or other solvent on them in a metal container with a tight-fitting lid. If they are not dripping with solvent they can be put in the garbage at the end of each day.

If cotton balls are dripping with polish remover, do not put them in the garbage until you squeeze the excess solvent into a separate container with a tight-fitting lid. Dispose of the solvent as hazardous waste.

Used Nail Polish Remover and Old Nail Polish

Dispose of unwanted nail polish, waste acetone and other waste nail polish removers as hazardous waste. You can take the waste to a hazardous waste treatment, storage, disposal or recycling facility (TSDR) drop off site or contract with a TSDR to pick it up from your business. **Do not** pour the acetone down your sink or toilet or put it in the garbage.

How to Store Used Nail Polish Remover and Other Chemicals

Keep a tight-fitting lid on all chemical containers and label each container with the name of the chemical and its hazard. For example, used nail polish remover should be labeled "Used Nail Polish Remover" and "Flammable".

A list of some chemicals found in nail salons is given below, and storage information is provided for each type. **Never mix them together:** doing this could result in a toxic reaction or fire!

Solvents: These include acetone, other nail polish removers and nail polish. All are flammables. Store flammables away from electrical outlets, stoves and other heat sources. Call your local fire department to find out how much flammable liquid you are allowed to store at your business and if you are required to store the flammables in a fireproof cabinet. Fire department regulations vary from city to city.

Produced by



as part of the **Local Hazardous Waste
Management Program in King County**

Page 1 of 4

SQG-NAILS-2 (5/04) rev. 5/07

This material is available in alternate formats for persons with disabilities by calling 206-263-3050 or 711 TTY.



Ammonia: Store away from flammables and bleach.

Bleach: Store away from flammables and ammonia.

Notifying Employees about Chemical Hazards

Your employees have a legal right to know about the hazards of the chemicals they work with. For this reason, you are required to keep a Material Safety Data Sheet (MSDS) for each chemical used in your businesses. Information on the MSDS will help you and your employees determine what safety precautions are needed for handling each chemical. When you purchase chemicals, you should receive an MSDS for each product from your vendor; if you don't, ask your vendor to provide one. Store the MSDS in an area in your salon where your employees can easily find them.

Some MSDSs are not clearly written and are difficult to understand. Call Washington State Department of Labor and Industries (L&I) consultation department at 206-515-2837 to help clarify the recommendations on the MSDS. (L&I Web-site: www.lni.wa.gov)

How to Use Less Solvent to Reduce Your Exposure

- Use a dispenser to apply the acetone or other solvent to cotton balls.
- Keep containers closed when you're not using them so solvent doesn't evaporate.
- Consider diluting the acetone to remove nail polish and acrylic nails. This can save money and protect your clients and yourself from chemical vapors. Try diluting your acetone by making a half solvent, half water mixture. Store it in a container with a tight-fitting lid and label it "50% water, 50% acetone." (If it is too weak to remove nails, it may still be effective in removing nail polish.)
- **Consider removing nails using the aluminum foil method**
Moisten a small cotton ball with acetone or other solvent and cover the acrylic fingernail with it. Wrap the fingertip with aluminum foil. Repeat this process for all fingernails, and then cover hands with new plastic gloves to hold the aluminum foil in place and keep the acetone from evaporating. Remove the cotton balls and foil and remove acrylic nails.

For instructions on how to dispose of the used cotton balls, refer to page one "Used Cotton Balls".



Selecting Nail Polish Removers-Acetone Substitutes

Are acetone substitutes safer than acetone?

The Local Hazardous Waste Management Program in King County reviewed various nail salon chemicals sold as substitutes for acetone and labeled as “non-acetone”. Many of these were advertised as safer than acetone. The study found that all substitutes had equivalent or higher health and environmental risks than acetone. For example, one nail polish remover labeled “non-acetone” contained 75 percent 2-propanone—another name for acetone.

No solvent, including acetone, is completely safe. Carefully review alternatives before switching to non-acetone products. For help in choosing a solvent, contact the Department of Labor and Industries or the Local Hazardous Waste Management Program in King County. Phone numbers are listed below.

Good Ventilation Reduces Chemical Exposure

To reduce the amount of chemicals you are exposed to you should have a system that circulates fresh air into your salon and pushes the indoor air out.

- Use a fan on one side of the salon that brings in fresh outside air. Use another fan on the other side of the salon to push the indoor air and chemical vapors out of the salon.
- Open windows on each side of the salon whenever possible.
- In addition to the fans you may want to use a downdraft table that vents to the outside.

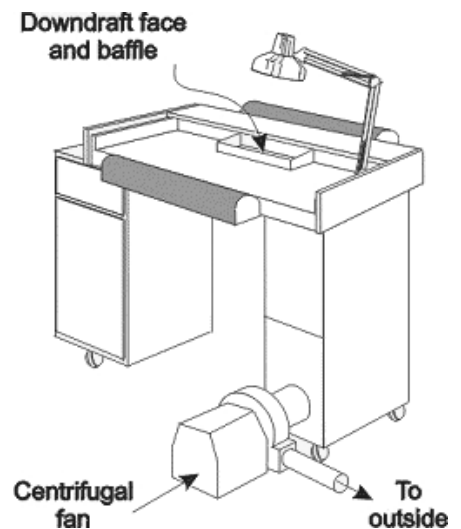

Safety Precautions-How to Prevent Injuries

- Read the MSDS for the chemicals used in your salon.
- Wear nitrile safety gloves that are resistant to solvents. (Latex gloves do not protect you from solvent exposure.)
- Wear safety glasses to protect eyes from sharp fingernail clippings and dust from grinding on nails.
- Maintain adequate ventilation.
(Note: Dust masks do not protect you from exposure to solvents—only from some airborne dust.)
- Contact the Department of Labor and Industries for recommendations on any additional personal protection gear you should use at your salon.

Look for safety equipment under “Safety Equipment and Clothing” in the yellow pages of the phone book.

Required Licenses

Washington State Department of Licensing

Contact the Department of Licensing for complete licensing requirements, including a list of notices that need to be posted at your salon. Some of the mandatory licenses/notices include:

- Business license (displayed in the salon entrance).
- Nail salon license (posted in direct public view).
- Original operators’ licenses with current photos attached (posted in the operator’s work station in view of clients).
- Various consumer guidance notices (posted with your license).

Note: Unlicensed salons or technicians will be subject to fines by the Department of Licensing Cosmetology Board.

Cosmetology Licensing Program

The Cosmetology Licensing Program, administered by the Department of Licensing’s Professional Licensing Support Services unit, is responsible for licensing, examination and regulatory compliance. It can be reached at 360-664-6626. Licensing requirements can also be found on the Web site at www.dol.wa.gov/professions.htm.

Safety Contacts

- Washington State Department of Labor and Industries,**
 Mark Soltow, CIH, Industrial Hygiene Consultant..... 206-515- 2837
- United States Food and Drug Administration**..... 425-483-4975

Hazardous Waste Disposal

(Companies listed in this brochure are not necessarily endorsed by King County.)

Drop-off services

- Philip Environmental Services, Renton..... 800-228-7872

Hazardous waste disposal facilities and brokers:

- Keep It Clean, Redmond..... 425-868-3535
- Kleen Environmental Technologies, Seattle..... 206-285-8010
- Safety-Kleen, Lynnwood..... 425-775-7030
- Safety-Kleen, (south), Auburn..... 253-939-2022

You can also call the Business Waste Line at 206-296-3976 or look in the Hazardous Waste Directory at www.govlink.org/hazwaste/business/wastedirectory/ for a current list of hazardous waste management companies.